

M COLLECTION - 70" STANCHIONS AND CROSSMEMBERS

INSTALLATION INSTRUCTIONS

STANCHIONS CAN BE INSTALLED ON TABLES WITH THE FOLLOWING WORK SURFACE SHAPES:

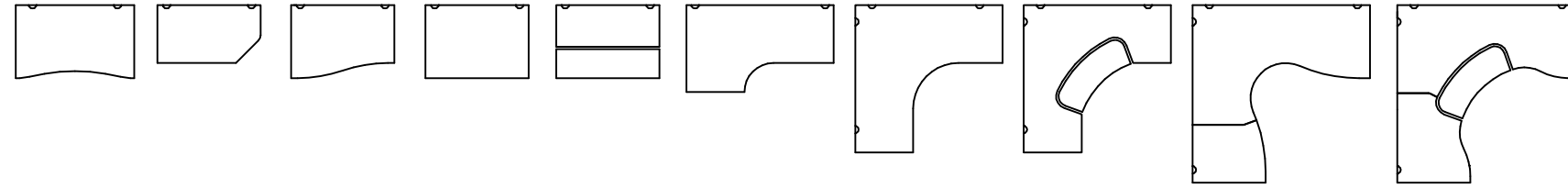

PRODUCTS:

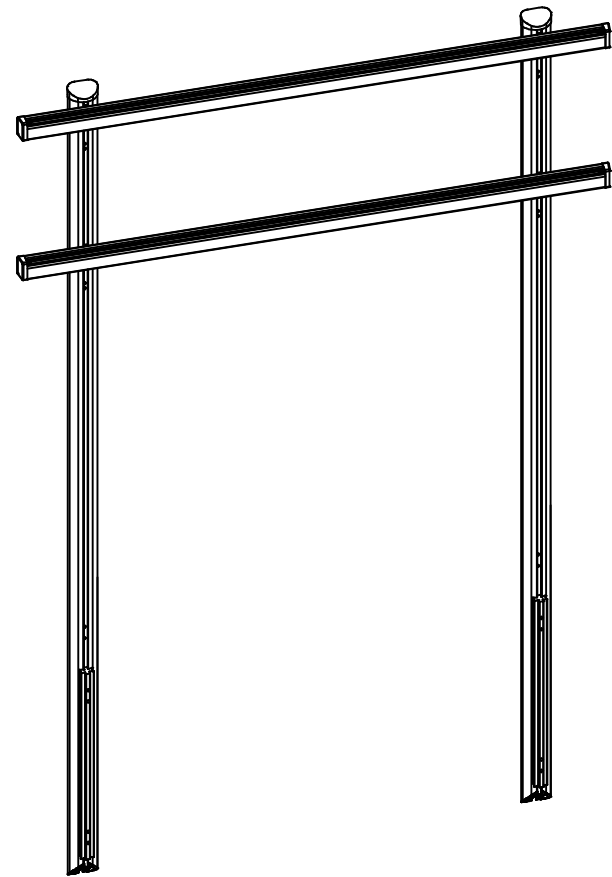

PARTS INCLUDED:

A 70" STANCHIONS
QTY: TWO (2)

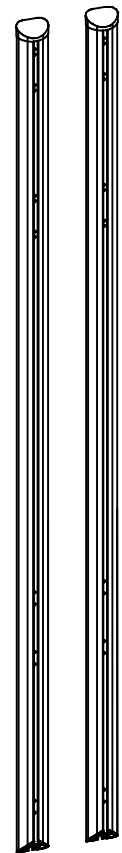

B CROSSMEMBERS
QTY: TWO (2)

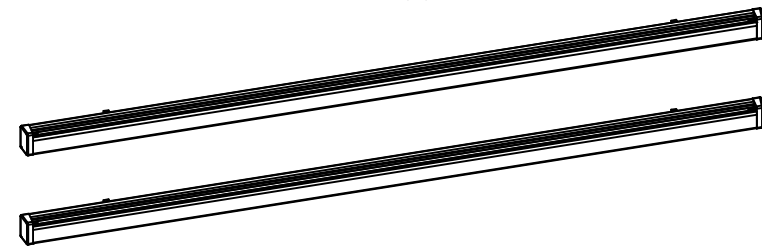

C STANCHION CONNECTORS
QTY: TWO (2)

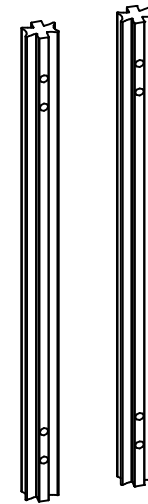

SEATED RANGE
(APPROX. 16 1/4" LONG)

OR



SIT-STAND / FIXED RANGE
(APPROX. 21 1/4" LONG)

D 10-24 X 2" SOCKET CAP SCREW
QTY: EIGHT (8)

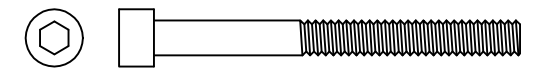

E 10-24 X 1" SOCKET CAP SCREW
QTY: EIGHT (8)

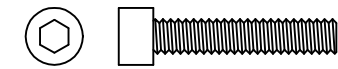

F GLIDE
QTY: TWO (2)

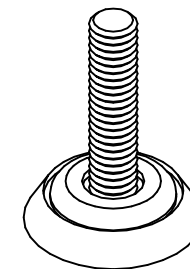

G CORD CLIP
QTY: FOUR (4)

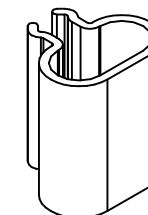

TOOLS REQUIRED:

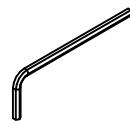

5/32" ALLEN WRENCH

M COLLECTION - 70" STANCHIONS AND CROSSMEMBERS

INSTALLATION INSTRUCTIONS

PROCEDURE:

1. MOVE TABLE TO POSITION THAT ALLOWS ACCESS TO REAR OF TABLE. INSTALL GLIDE IN CENTER OF BOTH FEET ON RECTANGULAR TABLE AND END FOOT ON ANY WORKCENTER TABLE. SCREW GLIDES INTO FEET AS FAR AS POSSIBLE.

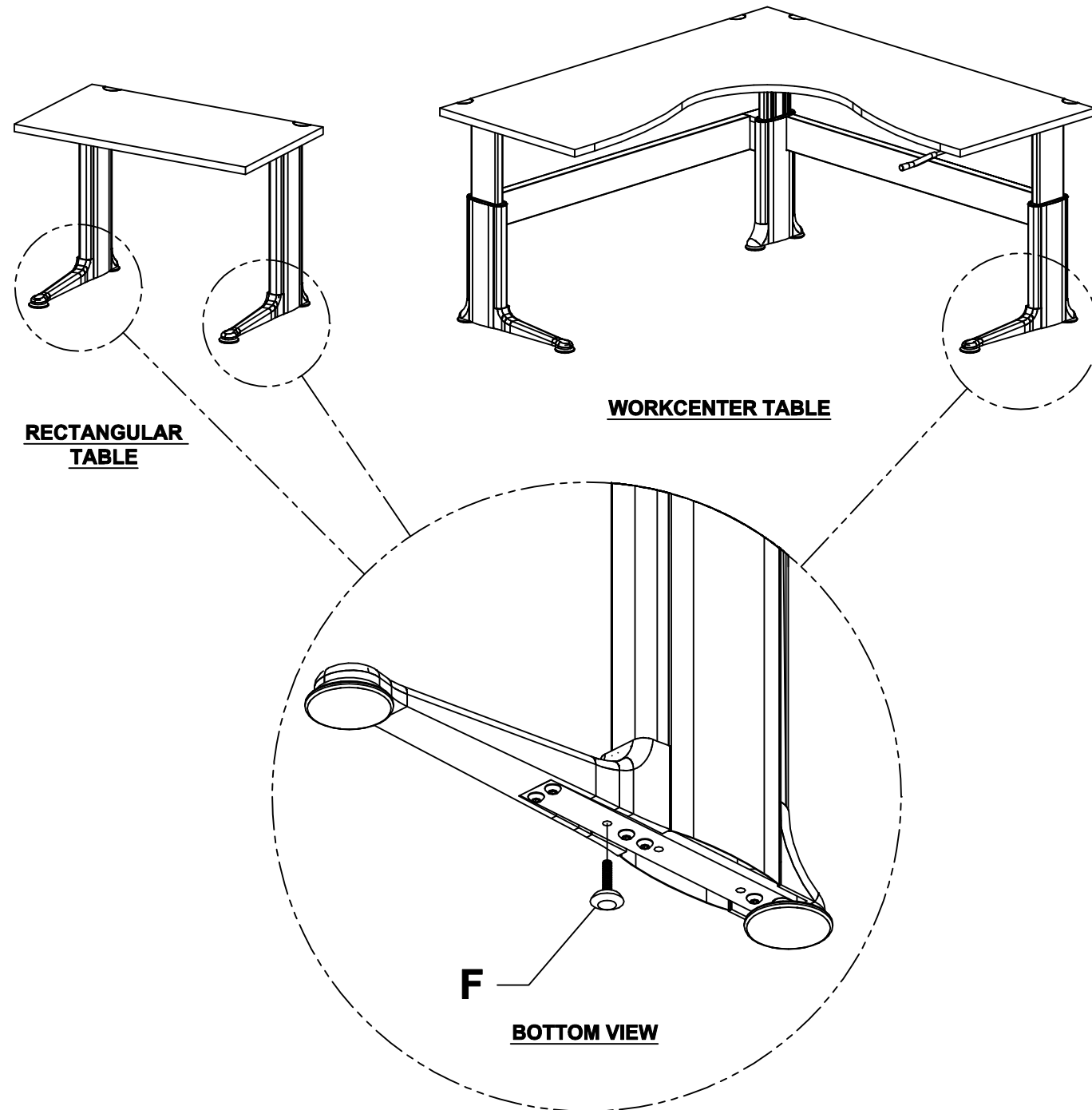

2. REMOVE GROMMETS FROM REAR EDGE OF WORKSURFACE AT STANCHION LOCATIONS.

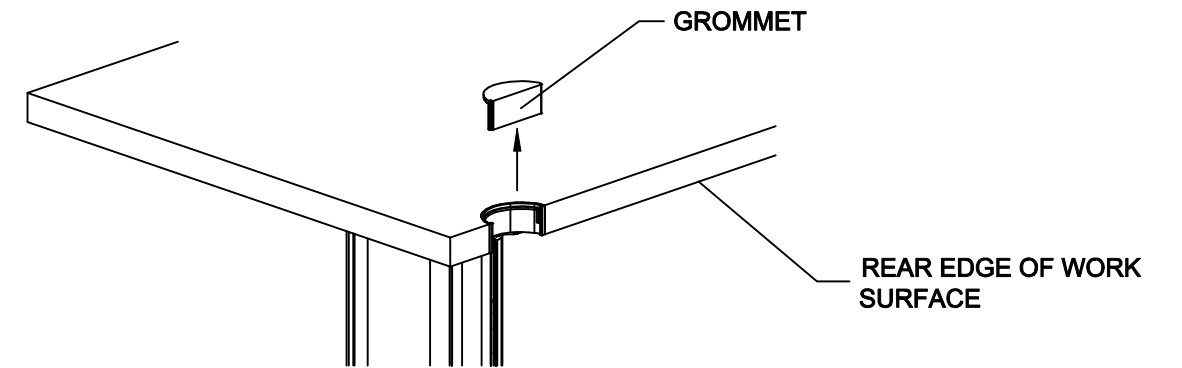

3. ATTACH STANCHIONS USING FOUR (4) 10-24 X 2" SOCKET CAP SCREWS FOR EACH STANCHION. SCREWS EXTEND THROUGH STANCHION AND STANCHION CONNECTOR AND THREAD INTO REAR OF COLUMN.

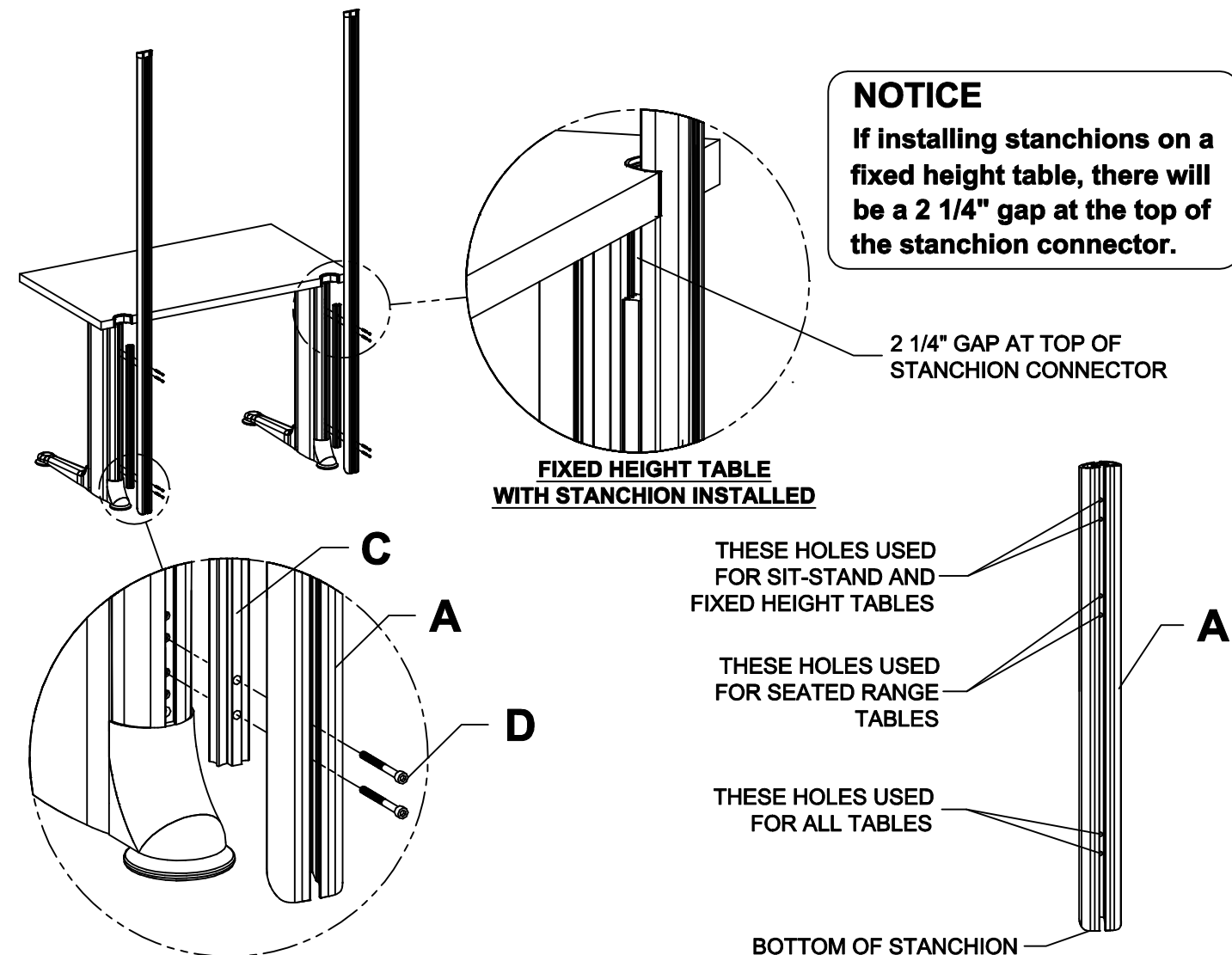

M COLLECTION - 70" STANCHIONS AND CROSSMEMBERS

INSTALLATION INSTRUCTIONS

PROCEDURE (CON'T):

- 4.** CHECK CROSSMEMBER MOUNTING BLOCK LOCATION BY LAYING THE CROSSMEMBER ACROSS THE WORK SURFACE WITH THE TOP GROOVE AWAY FROM THE STANCHION AND ALIGNING MOUNTING BLOCKS WITH GROOVES IN STANCHIONS. ENSURE THAT THE CROSSMEMBER DOES NOT EXTEND BEYOND THE EDGE OF THE WORKSURFACE. IF NECESSARY, MOVE THE MOUNTING BLOCKS TO THE REQUIRED LOCATION AND HAND TIGHTEN SCREWS.

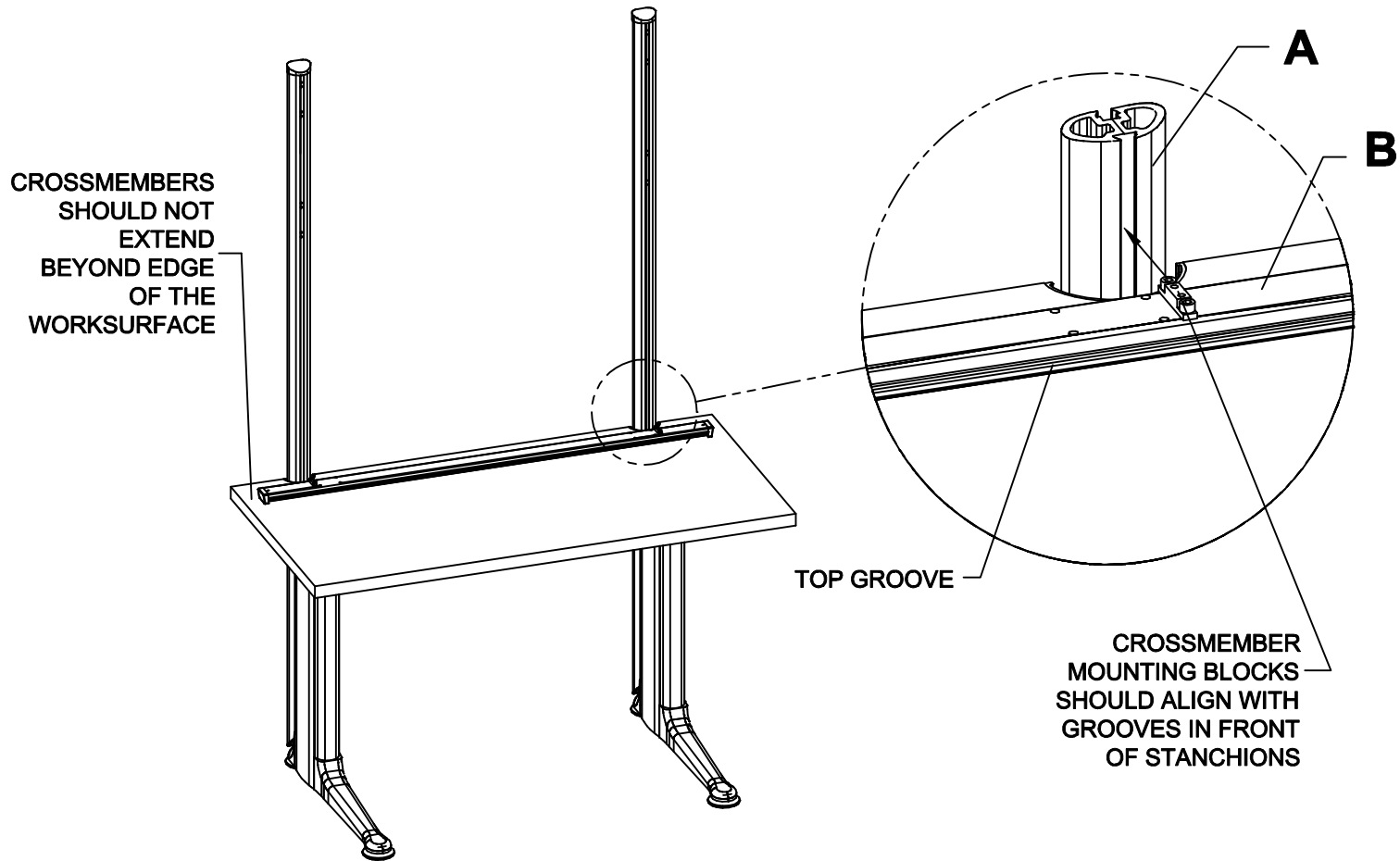

NOTICE

If necessary, move mounting blocks to required location. Remove mounting screws, move mounting block to required location and reinstall mounting screws. **HAND TIGHTEN SCREWS - DO NOT USE POWER SCREWDRIER**

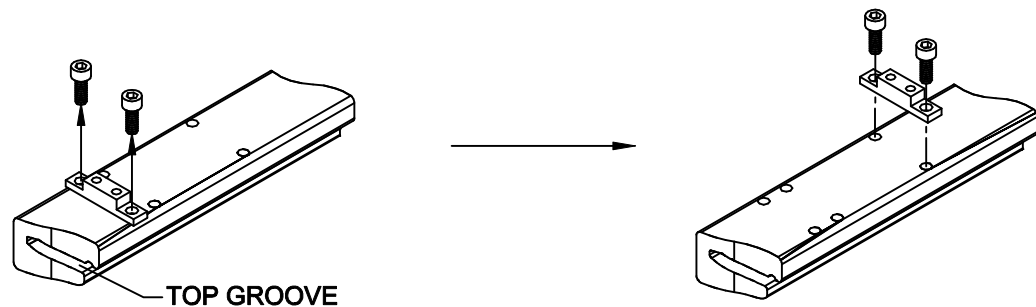

- 5.** ATTACH CROSSMEMBERS USING FOUR (4) 10-24 X 1" SOCKET CAP SCREWS FOR EACH CROSSMEMBER. ENSURE THAT THE GROOVE IN THE CROSSMEMBER IS FACING UPWARDS. SCREWS EXTEND THROUGH STANCHION AND THREAD INTO CROSSMEMBER MOUNTING BLOCKS. CROSSMEMBER MOUNTING BLOCKS FIT INTO THE GROOVES IN THE FRONT OF THE STANCHIONS.

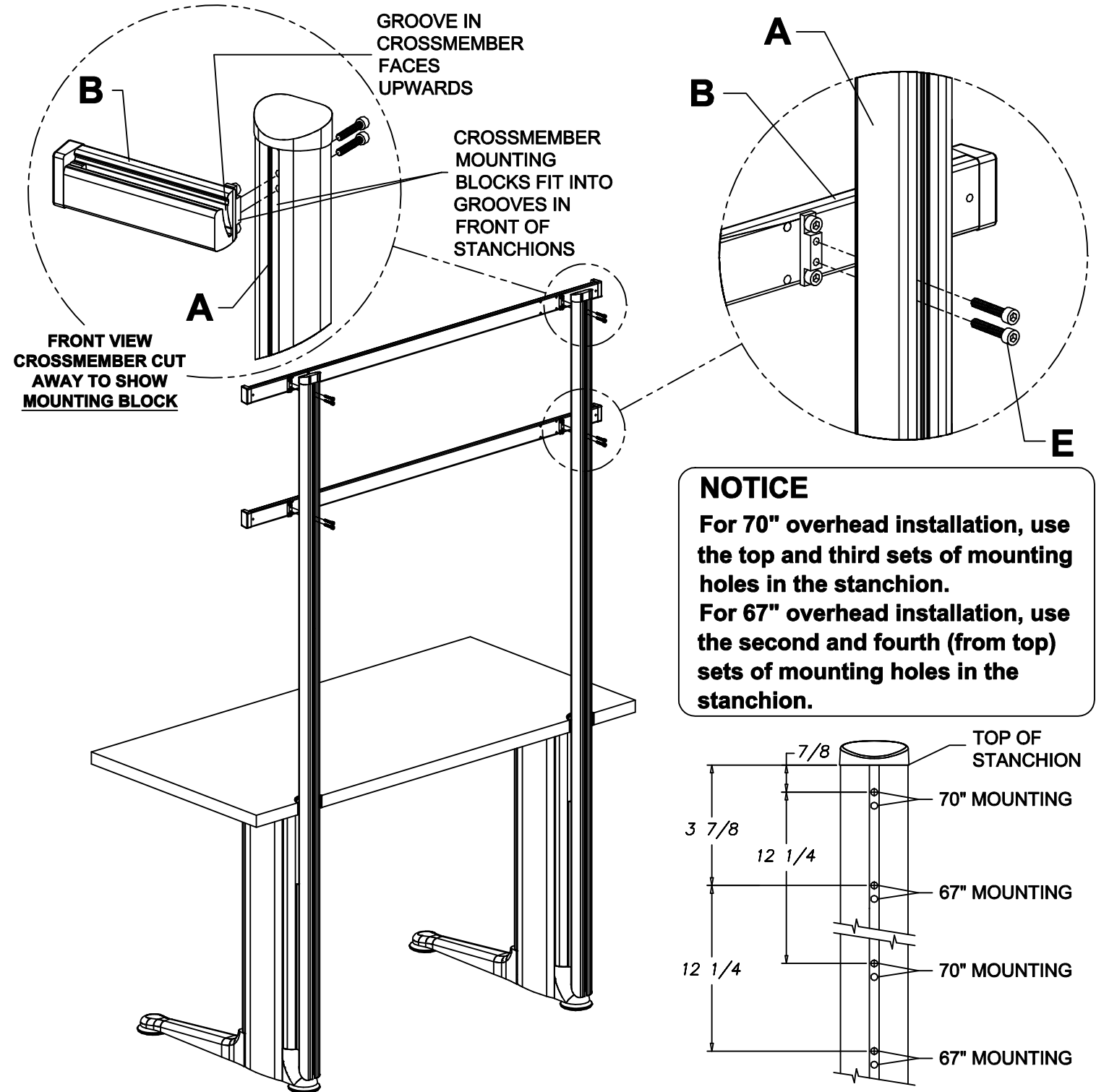

M COLLECTION - 70" STANCHIONS AND CROSSMEMBERS

INSTALLATION INSTRUCTIONS

P/N 21085-01 SHEET 4 OF 4

PROCEDURE (CON'T):

- 6.** CORD CLIPS SNAP FIT INTO VERTICAL SLOTS ON FRONT AND REAR OF STANCHIONS.

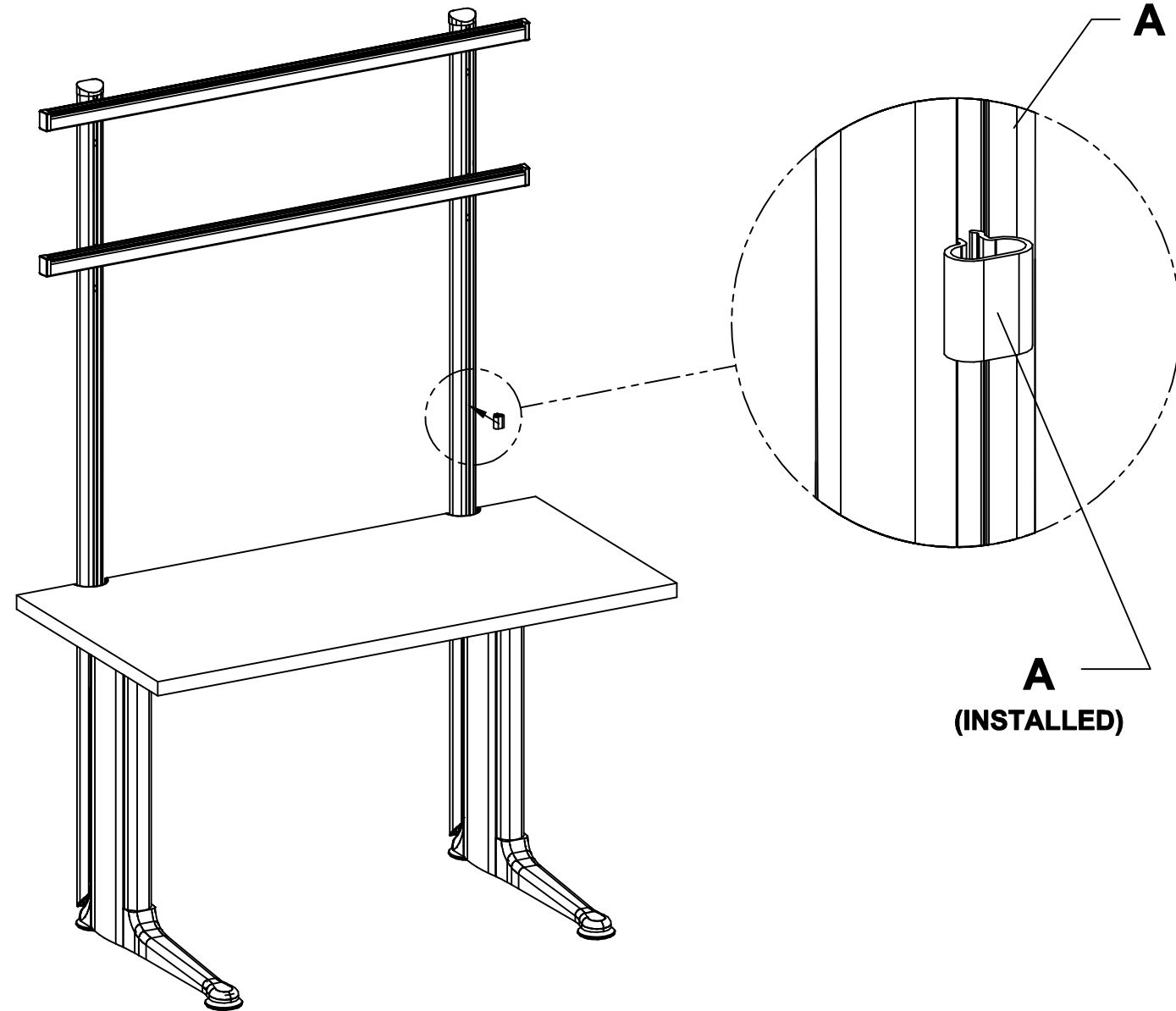

- 7.** MOVE TABLE INTO POSITION MAINTAINING PROPER CLEARANCE WITH ADJACENT SURFACES. ADJUST THE FRONT AND REAR GLIDES TO LEVEL THE TABLE. THEN EXTEND THE CENTER GLIDE TO THE FLOOR.

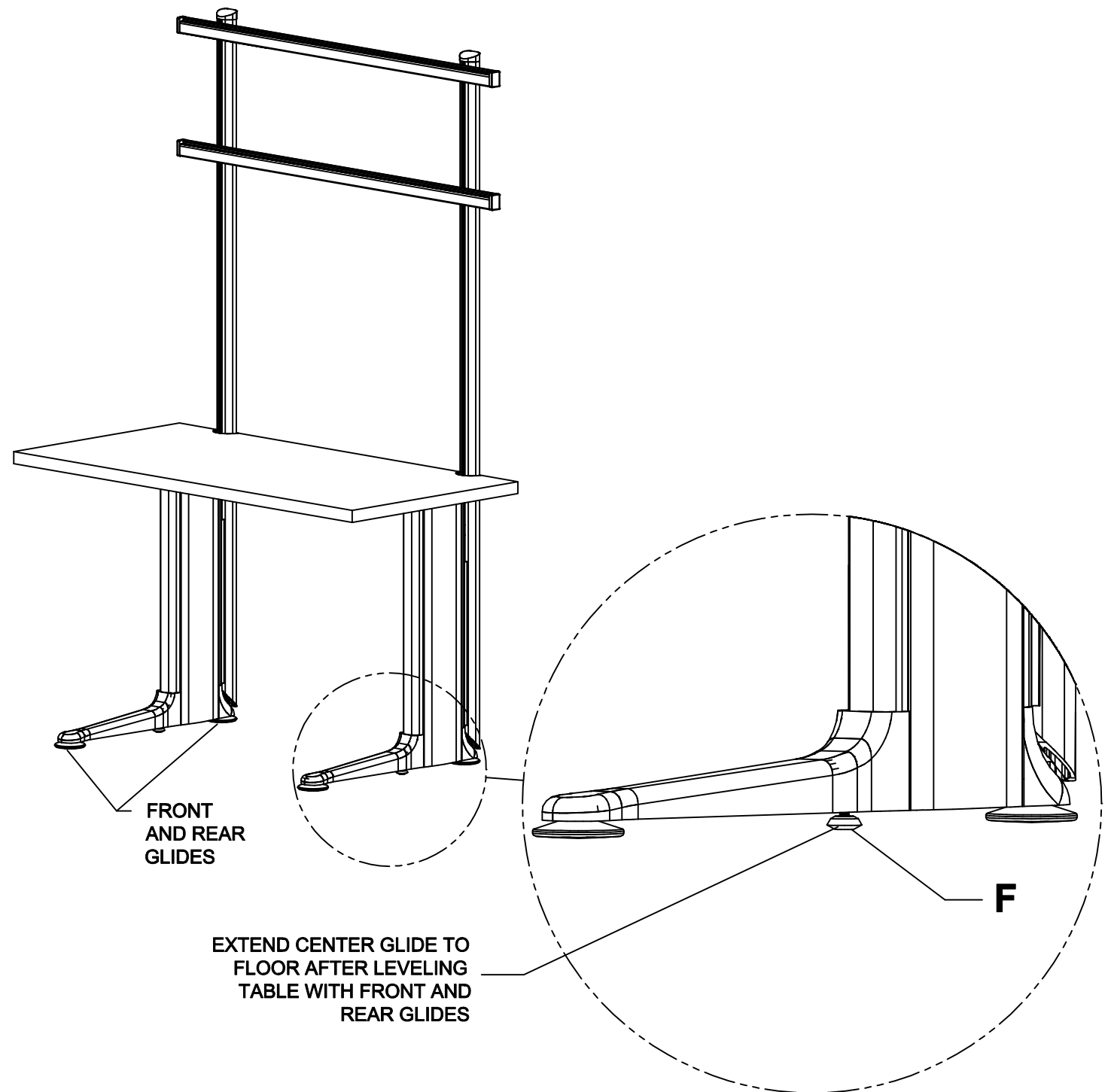

- 8.** ATTACH OVERHEAD STORAGE UNITS AS PER MANUFACTURER'S INSTALLATION INSTRUCTIONS.